

### Features

- 620 Watts peak pulse power ( $t_p=8/20\mu s$ )
- Protects Two Line Pairs (Four lines)
- Low capacitance
- Low leakage current
- Low operating and clamping voltage
- Solid-state Punch through Avalanche TVS process technology

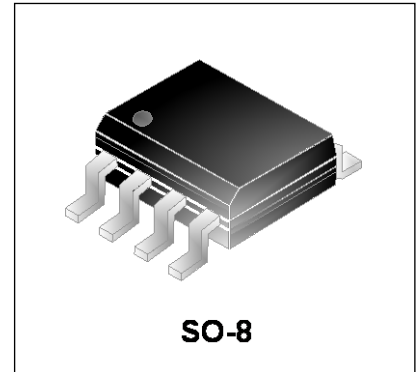

### IEC COMPATIBILITY (EN61000-4)

- IEC 61000-4-2 (ESD)  $\pm 30kV$  (air),  $\pm 30kV$  (contact)
- IEC 61000-4-4 (EFT) 40A (5/50ns)
- IEC 61000-4-5 (Lightning) 22A (8/20 $\mu s$ )

### Mechanical Characteristics

- JEDEC SO-8 package
- Marking: Marking Code
- Packaging: Tape and Reel
- RoHS Compliant

### Applications

- Switching Systems
- WAN/LAN Equipment
- Desktops, Servers, Notebooks & Handhelds
- 10/100, 1000M Ethernet
- Base Stations
- Audio/Video Inputs

### Schematic & PIN Configuration

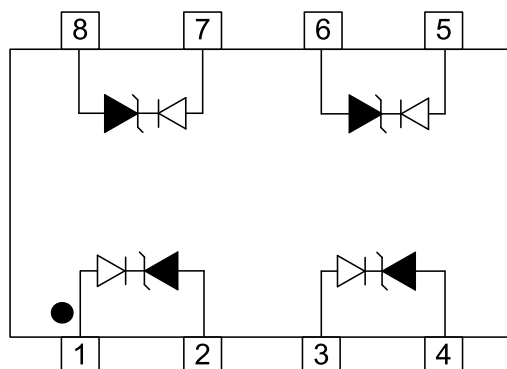

SO-8 (Top View)

Absolute Maximum Rating			
Rating	Symbol	Value	Units
Peak Pulse Power ( $t_p=8/20\mu s$ ) see Figure1 & Figure2	$P_{PP}$	620	Watts
Peak Pulse Current ( $t_p=8/20\mu s$ )	$I_{PP}$	22	A
Lead Soldering Temperature	$T_L$	260(10sec)	°C
Operating Temperature	$T_J$	-55 to + 125	°C
Storage Temperature	$T_{STG}$	-55 to +150	°C

Electrical Parameters (T=25°C)

Symbol	Parameter
$I_{PP}$	Reverse Peak Pulse Current
$V_C$	Clamping Voltage @ $I_{PP}$
$V_{RWM}$	Reverse Stand-Off Voltage
$I_R$	Reverse Leakage Current @ $V_{RWM}$
$V_{PT}$	Punch-through Voltage @ $I_{PT}$
$V_{SB}$	Snap-Back Voltage @ $I_{SB}$
$I_{SB}$	Snap-Back Test Current
$I_{PT}$	Test Current
$V_{PTF}$	Forward Breakdown Voltage @ $I_{PTF}$
$I_{PTF}$	Forward Test Current

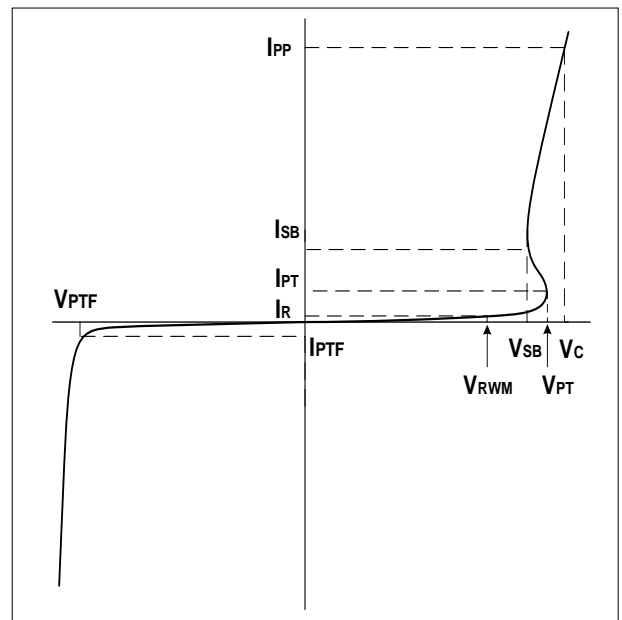

Electrical Characteristics(T=25°C)

WS2.8-4LVUB						
Parameter	Symbol	Conditions	Minimum	Typical	Maximum	Units
Reverse Stand-Off Voltage	$V_{RWM}$	See Note1			2.8	V
Punch-through Voltage	$V_{PT}$	$I_{PT}=2\mu A$ , See Note1	3.0		7	V
Reverse Leakage Current	$I_R$	$V_{RWM}=2.8V$ See Note1			100	nA
Snap-Back Voltage	$V_{SB}$	$I_{SB}=50mA$ ,See Note1	2.8			V

## Electrical Characteristics (Cont.)

Parameter	Symbol	Conditions	Minimum	Typical	Maximum	Units
Clamping Voltage ( Note2)	$V_C$	$I_{PP}=2A$ , $t_p=8/20\mu s$ See Note1			10	V
Clamping Voltage ( Note2)	$V_C$	$I_{PP}=5A$ , $t_p=8/20\mu s$ See Note1			13	V
Clamping Voltage ( Note2)	$V_C$	$I_{PP}=22A$ , $t_p=8/20\mu s$ See Note1			28	V
Junction Capacitance( Note3)	$C_j$	$V_R = 0V$ , $f = 1MHz$ See Note1		1.6	2.0	pF
Forward Breakdown Voltage	$V_{PTF}$	$I_{PTF} = 10\mu A$ See Note4	80			V
Dynamic Resistance <sup>1,2</sup>	$R_{DYN}$	TLP=0.2/100ns		0.6		$\Omega$
ESD Clamping Voltage <sup>1</sup>	$V_C$	$I_{PP} = 4A$ $t_p = 0.2/100ns$		8.6		V
ESD Clamping Voltage <sup>1</sup>	$V_C$	$I_{PP} = 16A$ $t_p = 0.2/100ns$		16.2		V

**NOTES:**

1. Device measured from pin 1 to 2, pin 3 to 4, pin 5 to 6 and pin 7 to 8.
2. The 8/20 $\mu s$  test pulse wave is shown in figure1, and the clamping voltage vs.  $I_{PP}$  is shown in figure3.
3. The Normalized Junction Capacitance vs. Reverse Voltage is shown in figure4.
4. Device measured from pin 2 to 1, pin 4 to 3, pin 6 to 5 and pin 8 to 7.

Typical Characteristics

Figure 1: Peak Pulse Power vs. Pulse Time

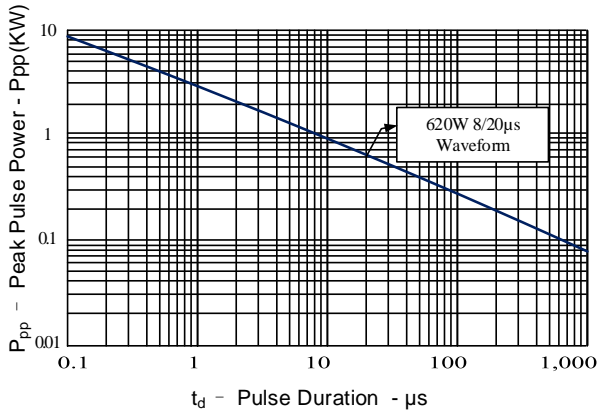

Figure 2: Power Derating Curve

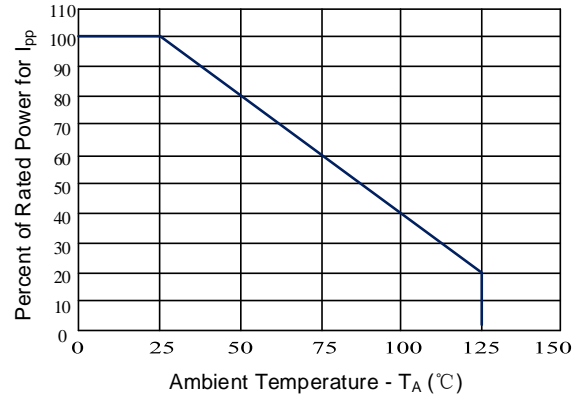

Figure 3: Clamping Voltage vs. Peak Pulse Current

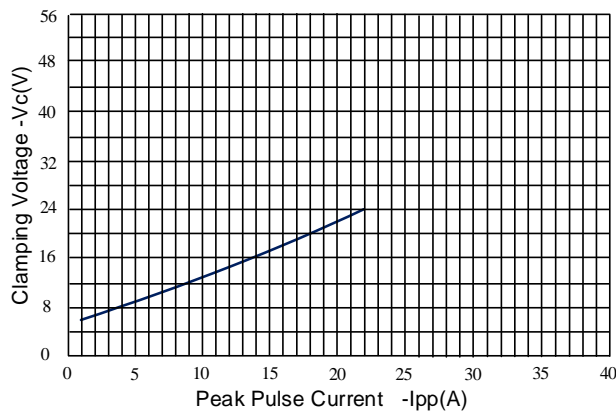

Figure 4: Normalized Junction Capacitance vs. Reverse Voltage

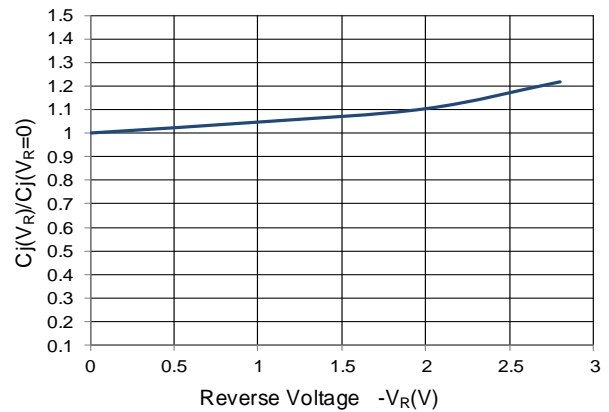

Figure 5: 8/20µs Pulse Waveform

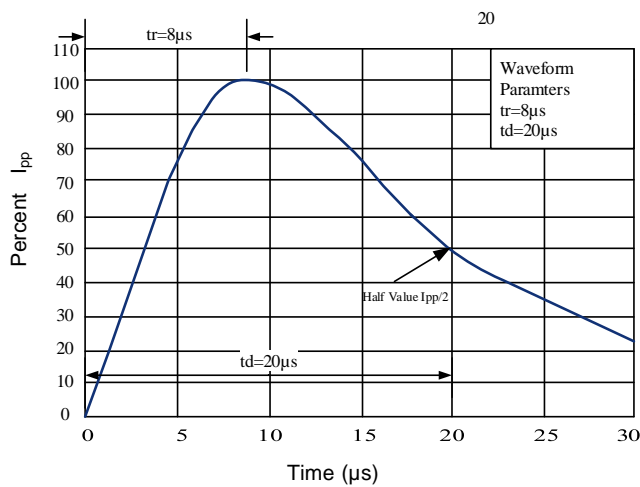
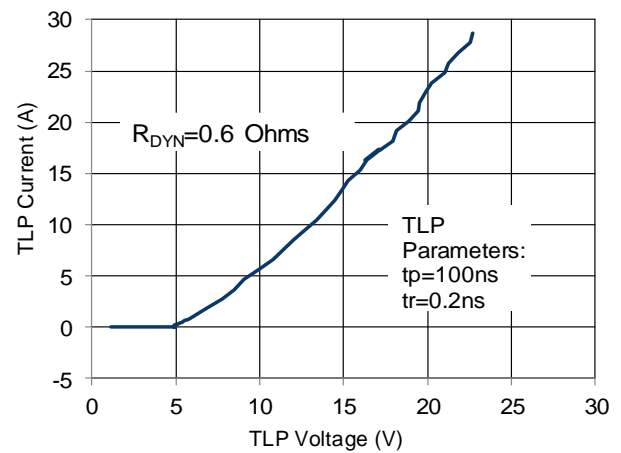

Figure 6: TLP Curve



## Application Information

The WS2.8-4LVUB is designed to providing protection for electronic equipment that is susceptible to damage caused by Electrostatic Discharge (ESD), Electrical Fast Transients (EFT) and tertiary lightning effects. This product is offered in a unidirectional configuration and provides both common-mode and differential-mode protection.

### Unidirectional Common-mode Protection

The WS2.8-4LVUB protects four lines in a common-mode configuration.

- Pin 1 is connected to Line1.
- Pin 3 is connected to Line2
- Pin 5 is connected to Line3.
- Pin 7 is connected to Line4
- Other Pins are connected to ground.

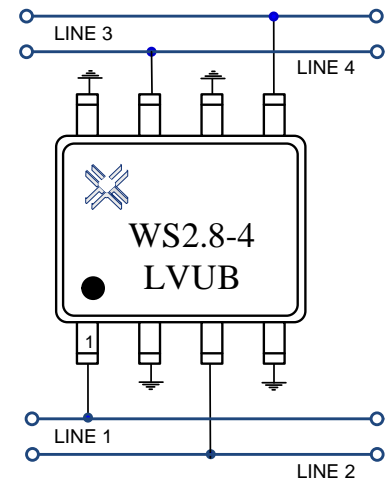

### Bidirectional Common-mode Protection

The WS2.8-4LVUB device provide two lines of bidirectional protection in a common-mode configuration.

- Pin1 & Pin8 are connected to Line1
- Pin4 & Pin5 are connected to Line2
- Other Pins are connected to ground.

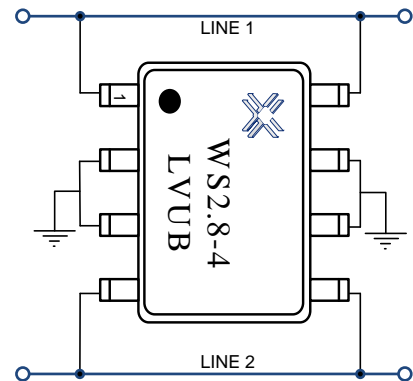

### Bidirectional Differential-mode Protection

The WS2.8-4LVUB device provide four lines of bidirectional protection in a differential-mode configuration.

- Pin1 & Pin8 is connected to Line1
- Pin2 & Pin7 is connected to Line2
- Pin3 & Pin6 is connected to Line3
- Pin4 & Pin5 is connected to Line4
- Line1&Line2 compose Line Pair1 ,Line3&Line4 compose Line Pair2

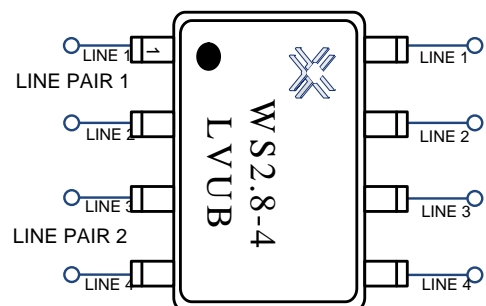

Main Application

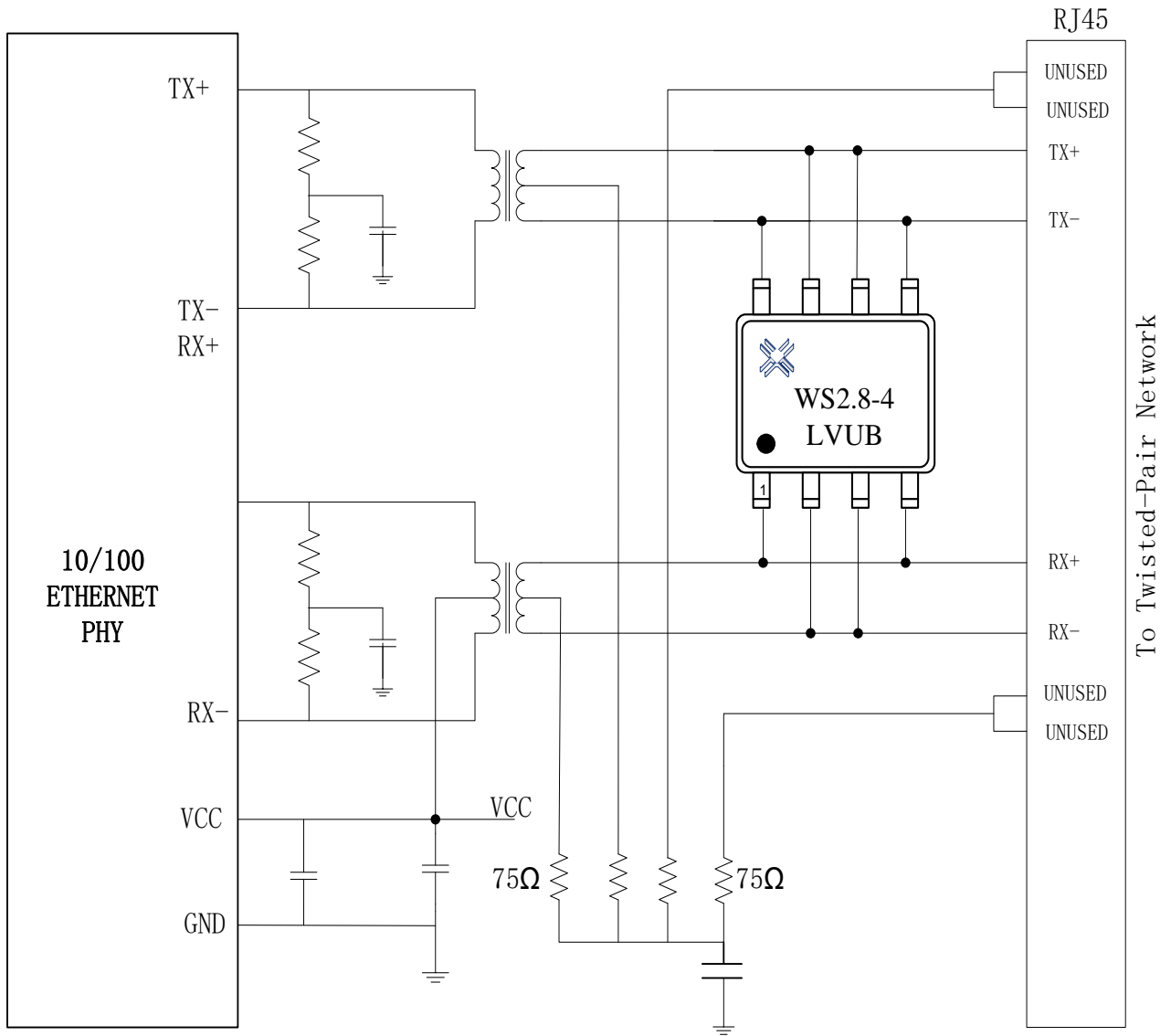

10/100 Ethernet Protection Circuit

Main Application (Cont.)

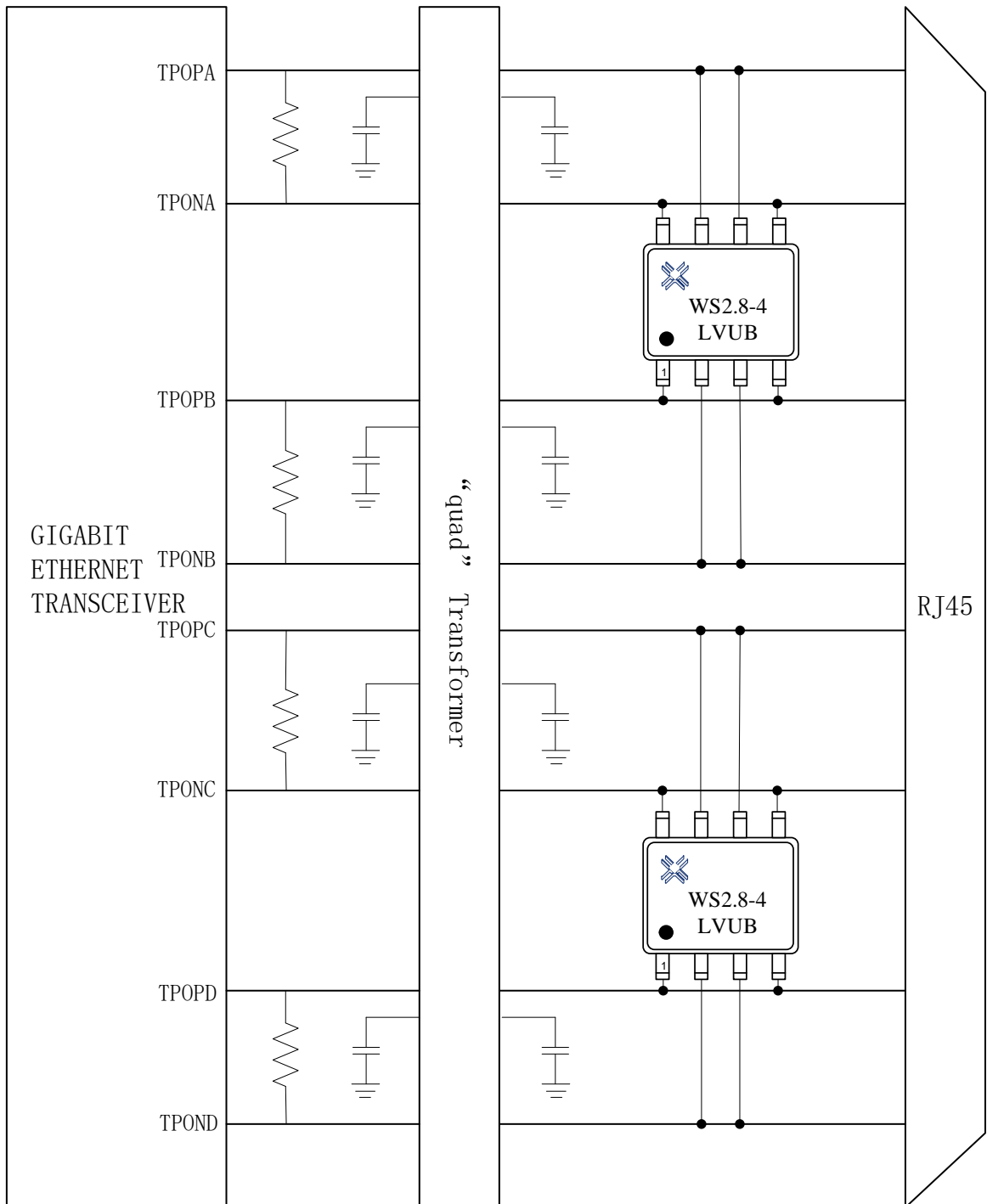

Gigabit Ethernet Protection Circuit

Soldering Parameters

Reflow Condition		Pb – Free assembly
Pre Heat	Temperature Min ( $T_{S(min)}$ )	150°C
	Temperature Max ( $T_{S(max)}$ )	200°C
	Time (min to max) ( $t_s$ )	60 – 190 secs
Average ramp up rate (Liquidus Temp) ( $T_L$ ) to peak		5°C/second max
$T_{S(max)}$ to $T_L$ —Ramp-up Rate		5°C/second max
Reflow	Temperature ( $T_L$ ) (Liquidus)	217°C
	Temperature ( $t_L$ )	60 – 150 seconds
Peak Temperature ( $T_P$ )		260+0/-5 °C
Time within actual peak Temperature ( $t_p$ )		20 – 40 seconds
Ramp-down Rate		5°C/second max
Time 25°C to peak Temperature ( $T_P$ )		8 minutes Max.
Do not exceed		280°C

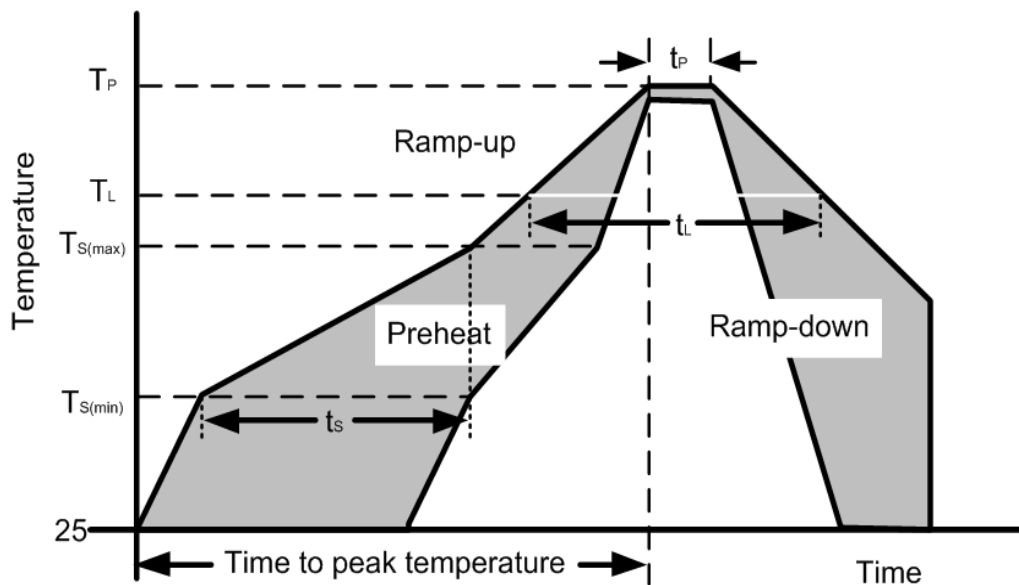



Outline Drawing – SO-8

**PACKAGE OUTLINE**

SO-8

**DIMENSIONS**

Symbol	INCHES			MILLIMETERS		
	MIN	NOM	MAX	MIN	NOM	MAX
A	0.053	-	0.069	1.35	-	1.75
A1	0.000	-	0.010	0.00	-	0.25
A2	0.049	-	0.065	1.25	-	1.65
b	0.012	-	0.020	0.31	-	0.51
c	0.007	-	0.010	0.17	-	0.25
D	0.185	0.193	0.201	4.70	4.90	5.10
E1	0.150	0.154	0.162	3.80	3.90	4.10
E	0.228	0.236	0.244	5.80	6.00	6.20
e	0.050 BSC			1.27 BSC		
L	0.016	-	0.050	0.40	-	1.27
θ	0°	-	8°	0°	-	8°
N	8			8		

DIMENSIONS		
DIM	INCHES	MILLIMETERS
C	(.205)	(5.20)
G	.118	3.00
P	.050	1.27
X	.024	0.60
Y	.087	2.20
Z	.291	7.40

**Notes:**  
Controlling Dimension: Millimeter.

Marking Codes

Part Number	WS2.8-4LVUB
Marking Code	WS2.8-4LVUB

Package Information

Qty: 2.5k/Reel

CONTACT INFORMATION

No.1001, Shiwan(7) Road, Pudong District, Shanghai, P.R.China.201207

Tel: 86-21-68969993 Fax: 86-21-50757680 Email: [market@way-on.com](mailto:market@way-on.com)

WAYON website: <http://www.way-on.com>

For additional information, please contact your local Sales Representative.

**WAYON** ® is registered trademark of Wayon Corporation.

Specifications are subject to change without notice.  
The device characteristics and parameters in this data sheet can and do vary in different applications and actual device performance may vary over time.  
Users should verify actual device performance in their specific applications.